



# zehnder *excelsior*

Owing to its design, Zehnder Excelsior provides inimitable illumination of the room. Streamlined oval tubes determine its design. Owing to their low liquid content, the radiators heat up quickly and almost instantly create a comfortable atmosphere in the room.

Various connection types and connection spacing allow their connection to new, as well as existing heating systems, assuring quick and easy installation.

Completo-type assembly with an internal valve and bottom connections and other types of connections can be provided by special order.

Custom-made models of Zehnder Excelsior radiators include: models, sloped to match the slope of the wall; curved and angled shapes; special models to be used as partitions and stair rails. Over 700 colours for you to choose from in the RAL catalogue.

Additional application possibilities based upon the wide range of available accessories.

**zehnder *excelsior***  
single-row assembly

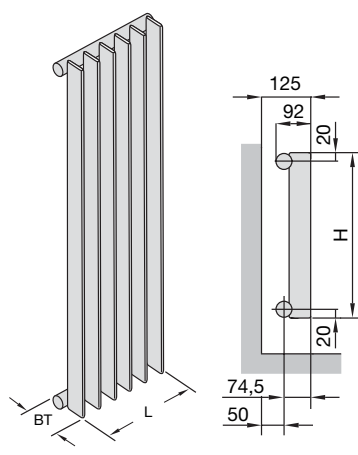

**zehnder *excelsior***  
double-row assembly

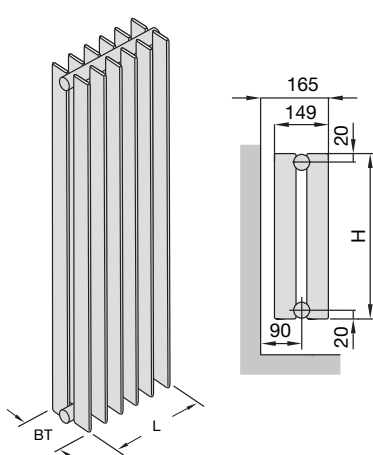

**zehnder *excelsior completo***

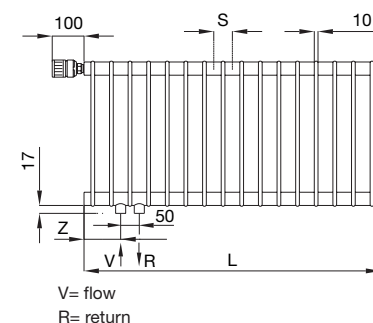

## Technical parameters

- L = Installation length from 120 to 3000 mm
- H = Installation height from 400 to 2500 mm
- BT = Installation depth 92 or 149 mm
- S = Distance between sections 30, 40, 50, or 60 mm
- WA = Distance from wall - depends on the type of brackets

## Operating pressure

- Standard
- High pressure (Special order)
- Operating temperature

- max. 5 bar (test 6.5 bar)
- max. 8 bar (test 10.4 bar)
- max. 120 °C

## Curved and angled assembly of Zehnder Excelsior radiators

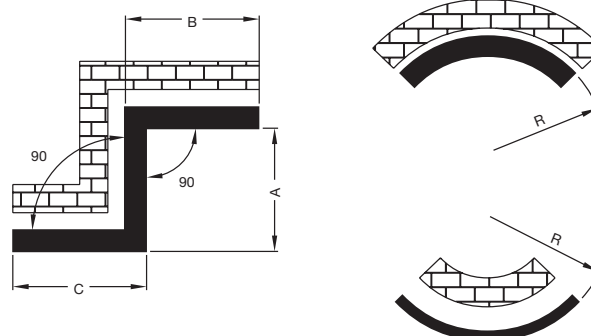

Zehnder Group  
Export Division  
Information Office  
Almweg 34  
D-77933 Lahr  
Tel. +49 (0) 7821 586 392  
Fax +49 (0) 7821 586 406  
zehnderexport@zehndergroup.com  
www.zehnder.eu



Zehnder Group  
Export Division  
Information Office  
7, rue Jean Mermoz  
F-91031 Evry Cedex  
Tél 33 1 69 36 16 15  
Fax 33 1 69 36 15 33  
export@zehndergroup.com  
www.zehnder.eu

**zehnder**